

c-Rover 5

Beam Transmissometer

Designed For Profiling Float systems

CRV5

User's Guide

This user's guide is an evolving document. If you find sections that are unclear or missing information, please let us know. Please check our website periodically for updates.

WET Labs, Inc.
PO Box 518
Philomath, OR 97370
(541) 929-5650
www.wetlabs.com



Return Policy for Instruments with Anti-fouling Treatment

WET Labs cannot accept instruments for servicing or repair that are treated with anti-fouling compound(s). This includes but is not limited to tri-butyl tin (TBT), marine anti-fouling paint, ablative coatings, etc.

Please ensure any anti-fouling treatment has been removed prior to returning instruments to WET Labs for service or repair.

c-Rover 5 Warranty

This unit is guaranteed against defects in materials and workmanship for one year from the original date of purchase. Warranty is void if the factory determines the unit was subjected to abuse or neglect beyond the normal wear and tear of field deployment, or in the event the pressure housing has been opened by the customer.

To return the instrument, contact WET Labs for a Return Merchandise Authorization (RMA) and ship in the original container. WET Labs is not responsible for damage to instruments during the return shipment to the factory. WET Labs will supply all replacement parts and labor and pay for return via 3rd day air shipping in honoring this warranty.

Instrument Shipping Requirements

1. Please retain the original shipping material. We design the shipping container to meet stringent shipping and insurance requirements, and to keep your meter functional.
 2. To avoid additional repackaging charges, use the original box (or WET Labs-approved container) with its custom-cut packing foam and anti-static bag to return the instrument.
 - If using alternative container, use at least 2 in. of foam (NOT bubble wrap or Styrofoam “peanuts”) to fully surround the instrument.
 - Minimum repacking charge for CRV meters: \$120.00.
 3. Clearly mark the RMA number on the outside of your shipping container and on all packing lists.
 4. Return instruments using 3rd day air shipping or better. **Do not** ship via ground.
-



Table of Contents

| | |
|--|-----------|
| 1. Setup and Operation | 1 |
| 1.1 Meter Setup and Functionality Check..... | 1 |
| 1.2 Mounting and Deployment | 2 |
| 1.3 Upkeep and Maintenance..... | 3 |
| 2. Specifications | 7 |
| 2.1 Output | 7 |
| 2.2 Connector..... | 7 |
| 3. Reference | 9 |
| 3.1 Input Voltage Reversal | 9 |
| 3.2 Mechanical Components..... | 9 |
| 3.3 Theory of Operation and Calibration..... | 9 |
| 4. Calibration and Validation | 11 |

1. Setup and Operation

WET Labs strongly recommends checking the functionality of the c-Rover 5 (CRV5) prior to any deployment.

The standard CRV5 delivery package includes the following:

- CRV5 meter
- This manual
- Meter-specific calibration sheet
- **Optional:** test cable

1.1 Meter Setup and Functionality Check

1. Connect the CRV5 to a regulated power supply at 12V and a host PC. WET Labs recommends using the optionally available test cable for pre-deployment checkout.
2. Run a terminal program such as HyperTerminal on the host PC.
 - Settings: 19200 baud; 8 data bits, 1 stop bit, no parity, no flow control.
3. Supply power to the meter.

Data is output from the instrument in the following order:

Column 1: CRV5 serial number , wavelength appended (R=red; G=green)

CRV5-030R 11829 13838 13695 0.003 527

Column 2: Reference raw count value CRV5-030R 11829 13838 13695 0.003 527

Column 3: Signal raw count value CRV5-030R 11829 13838 13695 0.003 527

| | | | | | | |
|--|-----------|-------|-------|-------|-------|-----|
| Column 4: Corrected signal count value | CRV5-030R | 11829 | 13838 | 13695 | 0.003 | 527 |
|--|-----------|-------|-------|-------|-------|-----|

Column 5: Calculated beam c, in inverse meters CRV5-030R 11829 13838 13695 0.003 527

Column 6: Internal thermistor raw count value CRV5-030R 11829 13838 13695 0.003 527

Refer to the Calibration Sheet that shipped with your CRV for its corrected signal count value. It will range between approximately 13000 and 16000 counts.

4. Block the light path and check that the corrected signal count is zero.

CRV5-030R 12683 0 0 -15.653 527



5. When you have verified the meter's output, turn off the power supply and disconnect the meter.

1.2 Mounting and Deployment

The instrument must be mounted to a float by its upper can only (see below). Clamping both ends will stress the center section, leading to optical instability and bad data. Clamping only to the lower can could allow tension to induce stresses in the center section resulting in poor data quality.

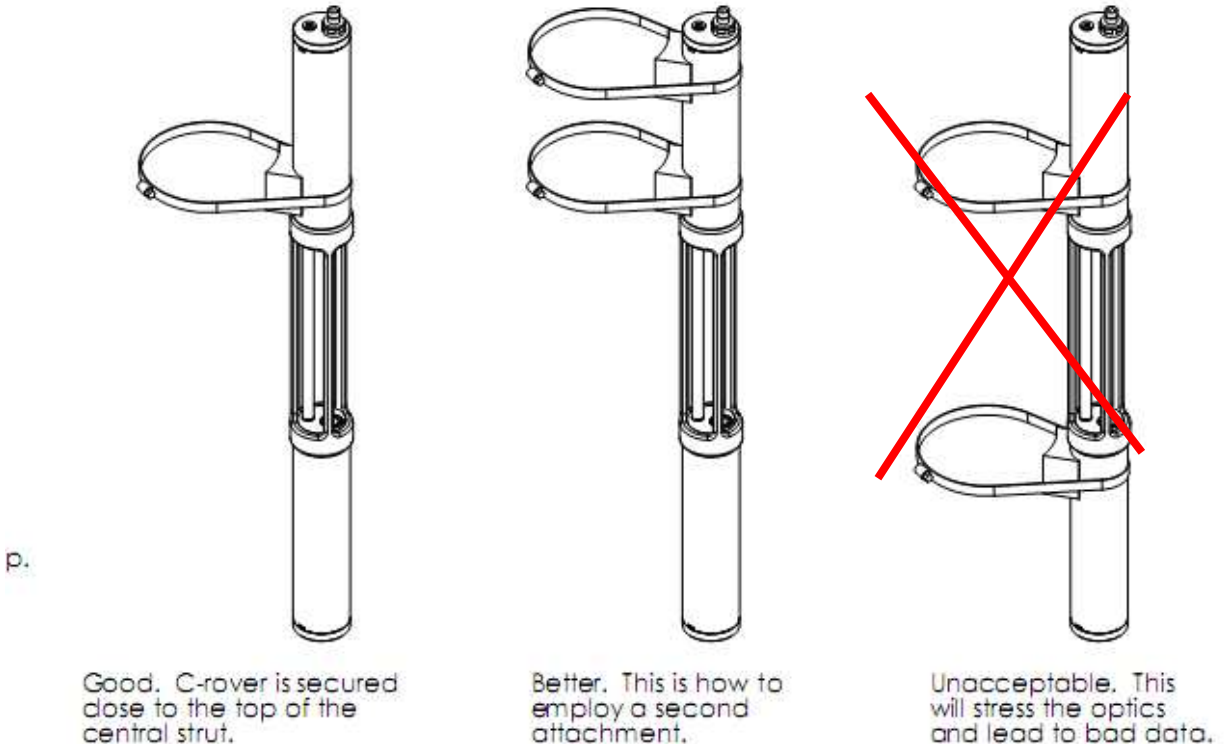

- ✓ Best practice: squirt a dilute solution of detergent onto the instrument prior to putting it into the water. This will help keep the optics clean through the surface layer of the water. After each operation or exposure of the instrument to natural water flush the instrument with clean fresh water, paying careful attention to the exposed optical faces. It is very important to make sure that salt water does not dry on the instrument as salt crystals are very persistent and can be difficult to remove. After flushing, a few squirts of a dilute solution of detergent onto the optical faces followed by a final rinse with filtered distilled water will keep the optic surfaces clean.

1.3 Upkeep and Maintenance

The CRV5 transmissometer is specifically designed for profiling floats where buoyancy is a primary consideration. It features low power consumption and weighs just 0.57 kg in water. For comparison, the deep C-Star transmissometer weighs 2.7 kg in water. The weight saving design makes the CRV5 a relatively delicate instrument. It is not rugged enough for normal ship-based operations.

This section describes routine processes to check that the instrument is functioning and providing good data. It is based on a standalone instrument and ECOView software. We also describe the routine maintenance required to keep the instrument functioning at its best. Please contact the profiling float designer and WET Labs if questions occur.

The CRV5 must be handled carefully to maintain its precise calibration. Do not squeeze the central struts. Do not drop it or set it down roughly. Do not twist the ends. The pressure housing is designed to withstand ocean pressure, not human abuse.



WARNING!

Opening the pressure housing will void the warranty. Additionally, the c-Rover 5 **must** be re-pressure tested prior to deployment. We cannot be responsible for leakage that occurs after the instrument has been opened by the user.

When stored, the instrument should be protected from dust and particularly from stack blow down if on deck. Prior to deployment, the instrument output should be evaluated. During missions, instrument output should be tracked.

The clean air output value for the instrument is provided on the factory calibration sheet. This is provided as the corrected signal counts in air: CSC_{air} . We recommend using the CSC_{air} value to:

1. monitor basic operation of the instrument,
2. decide when to clean the instrument,
3. decide when you have a clean instrument.

Tracking the CSC_{air} value over time is the single best way to monitor the performance of the instrument and maximize its utility.

We recommend a maintenance kit that consists of the following equipment (optionally available from WET Labs):

- Test cable
- 9 V battery
- A 500 ml squirt bottle of a dilute detergent solution. We recommend a commercial detergent such as Microclean or Dawn. Two drops of detergent in a 500 ml squirt bottle filled with 0.2 or 0.4 μ m filtered distilled and deionized water is sufficient.
- A 500 ml squirt bottle of 0.2 or 0.4 μ m filtered distilled and deionized water

- Lint-free laboratory wipes
- Cotton or lint-free swabs
- Compressed clean air source
- A notebook for recording maintenance dates and tracking output.

1.3.1 Check CRV5 Output

1. Connect the meter to a power supply and host PC.
2. Check the light source with a piece of white paper in the light path.



3. Block the light path and check that the corrected signal raw counts is zero.



Output:

CRV5-030R 12683 0 0 -15.653 527

The signal raw count value and the corrected signal raw count value should both go to zero. The calculated beam c value is not meaningful when the light value is blocked. Blocked values of a few counts above or below zero are not significant and can be ignored. Blocked values greater than 50 counts are a cause for concern and may indicate an instrument that needs to be serviced. Clean the optics and re-test. If a high blocked value persists, contact the WET Labs.

With the light path unobstructed, check that the corrected signal raw counts approaches the clean air value on the instrument's calibration sheet and/or previous tracking values.

CRV5-030R 12681 12977 12966 0.551 527

Clean air values will only approach or equal the factory air values in very controlled environments. If you are at sea you should expect to get within 500 counts. On shore in a controlled environment you should get within 100 counts. Larger differences between the current air values and the factory air values are a cause for concern and may indicate an instrument that needs to be serviced. Clean the optics and re-test. If a large difference persists, contact WET Labs.

1. Check for a “mid- range” value using a material that partially blocks the light, in this case a piece of tape.

Output:

CRV5-030R 12683 10523 10510 2.651 527



1.3.2 Cleaning the Optics

Follow the steps below to clean the optics. You should assume you will wet, clean and dry each optical surface several times before you reach a stable clean air value.

1. For routine cleaning of the optical faces, squirt a small amount of a dilute solution of detergent onto the optical face of the exposed glass window. We recommend using a commercial detergent such as Microclean or Dawn. Two drops of detergent in a 500 ml squirt bottle filled with 0.2 μm filtered distilled and deionized water is sufficient to break surface tension on the optical face and dislodge particles and minor surface oils.



Unfiltered DI water will also work, but may leave some particles on the optical surface. If the instrument is more severely fouled, use a standard detergent solution first and then follow with the dilute solution.

2. Use a “lint-free” laboratory cleaning wipe (e.g. a Kimwipe) to gently rub the optical surface to remove particles and fouling films.



You can also use a swab. Care must be taken that fibers do not remain on the optical surface.



3. Use compressed air to dislodge any final particles and dry the optical surface.



2. Specifications

| Mechanical | | Electrical | |
|---------------------|---------|---|------------|
| Height | 58.4 cm | Output resolution | 14 bit |
| Diameter | 6.91 cm | RS-232 output | 19200 baud |
| Weight in air | 1.9 kg | Connector (PEEK) | MCBH-6-MP |
| Weight in water | 0.57 kg | Power input | 7.5–15 VDC |
| Internal air volume | 636 cc | Operating current, typ., 532 and 650 nm | 35 mA |
| | | Operating current, max., 532 and 650 nm | 50 mA |
| | | Sample rate | to 8 Hz |

| Optical | | Environmental | |
|---------------------------|-----------------------------|---|----------------|
| Wavelengths* | 532 or 650 nm | Rated depth | 2000 m |
| Optical pathlength | 25 cm | Temperature range | 0–40 deg C |
| Acceptance angle | ~ 1.4 deg | Temperature stability cycled from 38–3–20 deg C | 0.02% FS/deg C |
| Precision, 532 and 650 nm | 0.002 m ⁻¹ @1 Hz | Long term stability (6 hrs) | 0.02% FS/Hr |
| Linearity | >99% R ² | | |

*532 nm is best for estimates of in-situ visibility.
650 nm is best for particle dynamics, e.g. mass concentration estimates.

Specifications are subject to change without notice.

2.1 Output

The RS-232 output from the digital CRV5 contains a mixture of character, integer, and floating point columns, described below. Note that RS-232 output is limited to a 15 ft. cable.

2.1.1 Serial Port Configuration

| Data Rate | Data Type |
|------------|---|
| 19200 baud | 8 data bits, 1 stop bit, no parity, no flow control |

2.2 Connector

The standard bulkhead connector for CRV is diagramed below.

| Pin | Function | MCBH-6-MP Connector diagram |
|-----|-------------|-----------------------------|
| 1 | Ground | |
| 2 | RS-232 (RX) | |
| 3 | Reserved | |
| 4 | V + | |
| 5 | RS-232 (TX) | |
| 6 | Reserved | |

WARNING!

Do not exceed the maximum input voltage specification of 15 volts.

3. Reference

3.1 Input Voltage Reversal

A series diode protects the CRV5 power supply from the reversal of input voltage polarity. As long as the reversed voltage is less than 30 V, the CRV5 power supply will not be damaged. After the system wiring has been corrected, the CRV5 power supply will then operate properly.

3.2 Mechanical Components

CRV5 has two pressure housings, one for the source electro-optics and one for the signal detection electro-optics. A rigid unistrut component connects these two housings, and provides a water tight conduit for connecting the electronics.

WARNING!

If the pressure housing is opened for any reason, your warranty will be voided. Additionally, the CRV5 **must** be re-pressure tested prior to using in the field. We cannot be responsible for leakage that occurs after the instrument has been opened by the user.

3.3 Theory of Operation and Calibration

The loss of light propagating through water can be attributed to two factors: scattering and absorption. Scattering and absorption of light are functions of the material in the water mass, both particulate and dissolved. By measuring with high precision the loss of light over a given distance the quantity and composition of the materials in a water mass can be inferred.

The ratio of light gathered by the CRV5's receiver to the amount originating at the source is the beam transmittance (Tr).

Transmittance is related to the beam attenuation coefficient “ c ” by the relationship

$$Tr = e^{-cx} \quad (1)$$

where x is the pathlength through the water volume, i.e. the distance between the source and receiver windows. The CRV5's pathlength is 25 cm.

The beam attenuation coefficient in natural waters is the sum of the beam attenuation coefficients for water (c_w), colored dissolved organic matter (c_g), and particles (c_p).

WET Labs has adopted the convention that the measured beam c is relative to the clean water calibration value, and hence does not include the beam attenuation coefficient for pure water at a given wavelength and temperature. Hence, for the CRV5, the measured beam c is:

$$c_{meas} = c_p + c_g \quad (2)$$

For the red version of the CRV5, the contribution of c_g can be assumed to be constant and negligible and hence the measured beam c is a function primarily of the particle mass concentration in a given water mass.

$$c_{meas} \cong c_p \quad (3)$$

For the green version of the CRV5, the contribution of c_g cannot be assumed to be constant and negligible. Instead, the measured beam attenuation coefficient for the green CRV5 can be related to the distance a human can discern a black object from the background by the relationship:

$$\text{Visibility (m)} = 4.6 / (c_{\text{meas}} + c_w) \quad (4)$$

3.3.1 Calibrated Instrument Output

CRV5 transmittance is expressed as

$$\text{Tr} = (\text{CSC}_{\text{sig}} - \text{CSC}_{\text{dark}}) / (\text{CSC}_{\text{cal}} - \text{CSC}_{\text{dark}}) \quad (5)$$

where:

- CSC_{sig} is the measured output signal
- CSC_{dark} is the dark offset for the instrument (factory-supplied). CSC_{dark} is obtained by blocking the light path.
- CSC_{cal} is the factory-supplied corrected signal counts for clean water.

The beam attenuation coefficient is calculated by:

$$c = -1/x * \ln(\text{Tr})$$

$$= -1/x * \ln[(\text{CSC}_{\text{sig}} - \text{CSC}_{\text{dark}}) / (\text{CSC}_{\text{cal}} - \text{CSC}_{\text{dark}})] \quad (6)$$

The corrected signal count value is derived from the signal raw count value after correction for instrument variance due to temperature. Most of this variance is due to inherent output changes in the LED. The signal is corrected by applying a linear ratio with slope and offset coefficients based on an optical reference measurement. This is accomplished in the instrument firmware as follows:

$$C_{\text{sig}} = M_{\text{sig}} * [C_{\text{slope}} * (M_{\text{ref}} / S_{\text{ref}}) + C_{\text{offset}}]$$

C_{sig} is defined as the Corrected Signal

M_{sig} is defined as the Measured Signal

C_{slope} is defined as the Correction fit Slope

C_{offset} is defined as the Correction fit Offset

S_{ref} is defined as the Set baseline Reference value

M_{ref} is defined as the Measured Reference

The correction slope and offset come from the equation of a best linear fit of relative signal to relative reference from a test temperature run. The temperature run is repeated with these coefficients loaded into the instrument to verify its internal correction performs to within the 0.02% full scale per deg C specification.

4. Calibration and Validation

Prior to shipment, each CRV5 is calibrated and tested to ensure that it meets the instrument's specifications. To measure the CRV5 output for calibration and validation, the CRV5 is connected to a 12 VDC power supply and a serial test cable. Meter output is captured on a PC with a terminal program using a standard RS-232 serial port.

The clean water calibration is performed using water from WET Lab's calibration facility. It goes through several stages of de-ionization, UV screening and ultra filtering to remove particles, bacteria and ions. This water is used to set the calibration value of corrected signal counts (CSC_{cal}) of the CRV5. This is obtained by filling the CRV5 beam path with clean water and measuring the output over 30–45 seconds. The windows are cleaned multiple times, and the highest counts observed are taken as the CSC_{cal} value.

Revision History

| Revision | Date | Revision Description | Originator |
|-----------------|-------------|-----------------------------|--|
| A | 6/11/09 | Draft (DCR 673) | A. Barnard, J. Kogler, D. Stahlke, I. Walsh, H. Van Zee |
| B | 9/15/10 | Draft (DCR 714) | H. Van Zee |