

# ***ECO VSF***

## Volume Scattering Function Meter

### **User's Guide**

*The user's guide is an evolving document. If you find sections that are unclear, or missing information, please let us know. Check our website periodically for updates.*

WET Labs, Inc.  
P.O. Box 518  
Philomath, OR 97370  
541-929-5650  
fax: 541-929-5277  
[www.wetlabs.com](http://www.wetlabs.com)



## ECO Sensor Warranty

This unit is guaranteed against defects in materials and workmanship for one year from the original date of purchase. Warranty is void if the factory determines the unit was subjected to abuse or neglect beyond the normal wear and tear of field deployment, or in the event the pressure housing has been opened by the customer.

To return the instrument, contact WET Labs for a Return Merchandise Authorization (RMA) and ship in the original container. WET Labs is not responsible for damage to instruments during the return shipment to the factory. WET Labs will supply all replacement parts and labor and pay for return via 3<sup>rd</sup> day air shipping in honoring this warranty.

## Shipping Requirements

1. Please retain the original shipping material. We design the shipping container to meet stringent shipping and insurance requirements, and to keep your meter functional.
2. Clearly mark the RMA number on the outside of your shipping container and on all packing lists.
3. Return instruments using 3<sup>rd</sup> day air shipping or better: do **not** ship via ground.

## Return Policy for Instruments with Anti-fouling Treatment

WET Labs cannot accept instruments for servicing or repair that are treated with anti-fouling compound(s). This includes but is not limited to tri-butyl tin (TBT), marine anti-fouling paint, ablative coatings, etc.

Please ensure any anti-fouling treatment has been removed prior to returning instruments to WET Labs for service or repair.



Electrical equipment marked with this symbol may not be disposed of in European public disposal systems. In conformity with EU Directive 2002/96/EC (as amended by 2003/108/EC), European users of electrical equipment must return old or end-of-life equipment to the manufacturer for disposal at no charge to the user.



## Table of Contents

<b>1. Specifications .....</b>	<b>1</b>
1.1 Connectors .....	2
1.2 Delivered Items .....	3
1.3 Optional Equipment .....	4
<b>2. Theory of Operation .....</b>	<b>6</b>
<b>3. Instrument Operation .....</b>	<b>7</b>
3.1 Initial Checkout .....	7
3.2 Operating the Sensor for Data Output .....	7
3.3 <i>Bio-wiper™</i> Operation .....	8
3.4 Deployment .....	8
3.5 Upkeep and Maintenance .....	9
<b>4. VSFB and VSFSB: Using Internal Batteries .....</b>	<b>12</b>
4.1 Removing End Flange and Batteries .....	12
4.2 Replacing End Flange and Batteries .....	13
4.3 Checking Vent Plug, Changing O-Rings: .....	14
<b>5. Data Analysis .....</b>	<b>15</b>
5.1 Data Corrections .....	15
5.2 Determining other Angle-Specific Coefficients .....	16
<b>6. Testing and Calibration .....</b>	<b>17</b>
6.1 Testing .....	17
6.2 Calibration .....	17
<b>7. General Terminal Communications .....</b>	<b>20</b>
7.1 Communication Settings .....	20
7.2 <i>ECO</i> Command List and Data Format .....	20
<b>8. Device and Output Files .....</b>	<b>21</b>
8.1 Plot Header .....	21
8.2 Column Count Specification .....	21
8.3 Column Description .....	21
8.4 Sample Device File .....	22
8.5 Sample Output File .....	22
<b>Appendix A: Mounting Bracket Drawing .....</b>	<b>23</b>



## 1. Specifications

Model	VSF(RT)	VSF	VSFS	VSFB	VSFSB
<b>Mechanical</b>					
Diameter	6.3 cm				
Length	12.7 cm		13.3 cm	27.4 cm	27.99 cm
Weight, in air	0.4 kg		0.5 kg	0.96 kg	
Material	Acetal copolymer				
<b>Environmental</b>					
Temperature range	0–30 deg C				
Depth rating	600 m		300 m		
Optional pressure sensor	--			Y	
Optional thermistor	--			Y	
<b>Electrical</b>					
Output resolution	12 bit				
Internal data logging	N			Y	
Internal batteries		N		Y	Y
Connector	MCBH6MP				
Input	7–15 VDC				
Current, typical	60 mA				
Current, sleep	140 $\mu$ A				
Data memory	--	77,000 samples			
Sample rate	to 8 Hz				
RS-232 output	19200 baud				
Optional Anti-fouling bio-wiper™		N	Y	N	Y
Bio-wiper™ cycle	-	-	140 mA		
<b>Optical</b>					
Wavelength	470, 532, or 650 nm				
Sensitivity	0.003 m <sup>-1</sup>				
Range, typical	0–5 m <sup>-1</sup>				
Linearity	99% R <sup>2</sup>				

**VSF(RT)**—Provides an RS-232 serial output with 4000-count range. This unit can be programmed for continuous operation.

**VSF**—Provides an RS-232 serial output with 4000-count range. This unit can be programmed for continuous operation or periodic sampling.

**VSFS**—Provides the capabilities of the VSF with an integrated anti-fouling *Bio-wiper*™.

**VSFB**—Provides the capabilities of the VSF and self-recording with internal batteries for autonomous operation.

**VSFSB**—Provides the capabilities of the VSF with an integrated anti-fouling *Bio-wiper*™ and self-recording with internal batteries for autonomous operation.

*Specifications subject to change without notice.*

## 1.1 Connectors

*ECO* VSF meters use a six-pin bulkhead connector. The pin functions for this connector are shown in Figure 1. Table 1 summarizes pin functions for the bulkhead connectors.

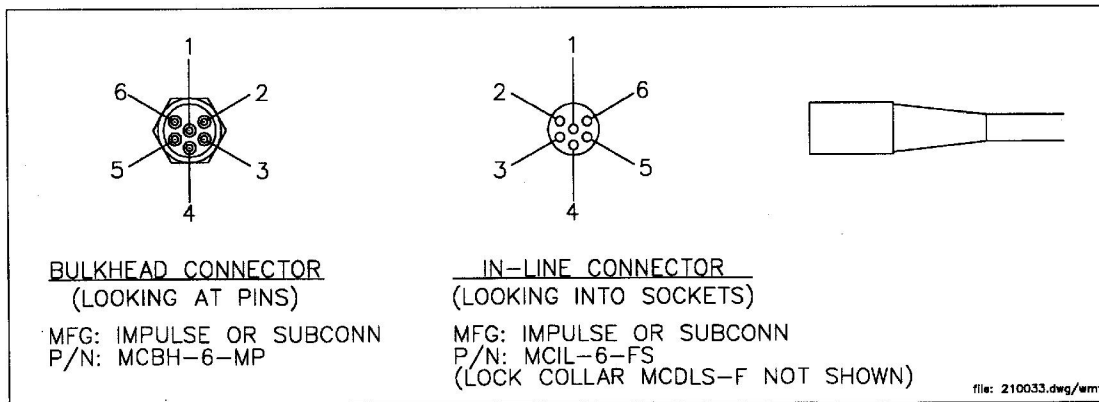

**Figure 1.** *ECO* VSF connector schematic

**Table 1.** Pinout summary for *ECO* connectors

Pin (or Socket)	Function
1	Ground
2	RS-232 (RX)
3	Reserved
4	V In
5	RS-232 (TX)
6	Configurable

### WARNING

**If you are going to build or use a non-WET Labs-built cable, do not use the wire from pin 3 or the *ECO* meter will be damaged.**

Input power of 7–15 volts DC is applied to pin 4. The power supply current returns through the common ground pin. The input power signal has a bi-directional filter. This prevents external power supply noise from entering into the *ECO* VSF, and also prevents internally generated noise from coupling out on to the external power supply wire. Data is sent out pin 5.

### 1.1.1 *ECO* VSFB and VSFSB Connectors

*ECO* VSFB and VSFSB (units with internal batteries) have an second bulkhead connector that comes with a jumper plug to supply power to the unit. The pin functions for this connector are shown in Figure 2. Table 2 summarizes pin functions for the 3-socket bulkhead connector.

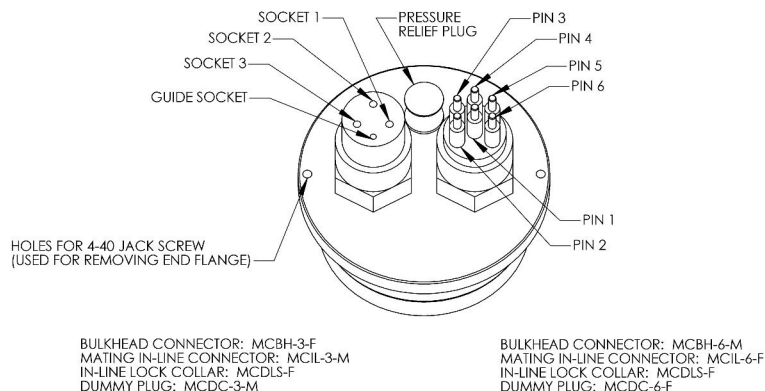

**Figure 2.** ECO VSFB and VSFSB connector schematic

**Table 2.** Pinout summary for *ECO* 3-socket connector

Pin (or Socket)	Function
1	V in
2	N/C
3	Battery out

## 1.2 Delivered Items

The standard VSF delivery consists of the following:

- the instrument itself
- protective cover for optics
- dummy plug with lock collar
- this user's guide
- ECOView user's guide
- ECOView host program and device file (on CD)
- instrument-specific calibration sheet
- VSF(RT), VSF, VSFS: stainless steel mounting bracket and hardware (See Appendix A for details)
- One 3/32-in. hex key for *bio-wiper*™ removal
- Three 4-40 x 3/8 in. 316 stainless steel replacement screws for *bio-wiper*™
- Internal battery units: six 9-V Lithium batteries (installed)
- spare parts kit (battery units only):
  - Two end flange O-rings (size 224)
  - Two vent plug O-rings (size 010)
  - Two jacking screws for connector flange removal
  - One 3/32-in. hex key for jacking screws
  - Power plug for autonomous operation
  - Three pre-cut segments (7 inches) of 0.036-inch diameter monofilament for end flange
  - Three pre-cut segments (0.25 inches) of 0.094-inch diameter white nylon bar stock for replacing the white plastic dowel pin

---

## 1.3 Optional Equipment

### 1.3.1 Test Cable

A test cable is supplied with each unit. This cable includes three legs:

1. A connector for providing power to the instrument from a user-supplied 9V battery.
2. A DB-9 serial interface connector.
3. A six-socket in-line connector for providing power and signal to the instrument.

### 1.3.2 Copper Faceplate

ECO meters are optionally equipped with copper faceplates to improve the meter's resistance to biofouling. Refer to Section 3.5.1 for important details on maintenance and cleaning.

### 1.3.3 Bio-wiper<sup>™</sup> and Copper Faceplate

The BBS and BBBS are equipped with an integrated non-contact anti-fouling *bio-wiper*<sup>™</sup> and copper faceplate for use in extended deployments. This wiper can be manually controlled by a host controller package, or can perform autonomously as part of a pre-programmed sampling sequence upon instrument power-up. The rate of opening and closing depends on both temperature and depth.

Refer to Section 3.5.1 for important details on the maintenance and cleaning of the *Bio-wiper*<sup>™</sup> and copper faceplate.

### WARNING!

Do **NOT** rotate the *Bio-wiper*<sup>™</sup> manually. This can damage the wiper motor and will void the warranty.

---

### 1.3.4 Batteries

ECO units with internal batteries are supplied with six 9-volt Lithium batteries as their power source. They can use either standard alkaline cells for a total capacity of approximately 1000 mA-hrs, or for longer deployments, LiMnO<sub>2</sub> cells to achieve more than 2000 mA-hrs of operational capacity. Actual total usage time of the internal batteries is a function of several parameters. These include nominal water temperature, sequence timing, sample periods, and total deployment duration.

### 1.3.5 External Thermistor

ECO meters are optionally equipped with an external thermistor. The thermistor is calibrated at WET Labs and the calibration coefficients are supplied on the instrument's calibration sheets. Thermistor output is in counts and can be converted into engineering units using the instrument's device file and ECOView software or the raw data can be converted in the user's software (e.g. MATLAB or Excel) using the calibration equation:

Temperature (deg C) = (Output \* Slope) + Intercept

### 1.3.6 Pressure Sensor

ECO meters are optionally equipped with a strain gauge pressure sensor. The pressure sensor is calibrated at WET Labs and the calibration coefficients are supplied on the

instrument's calibration sheets. Pressure sensor output is in counts and can be converted into engineering units using the instrument's device file and ECOView software or the raw data can be converted in the user's software (e.g. MATLAB or Excel) using the calibration equation:

$$\text{Relative Pressure (dbar)} = (\text{Output} * \text{Slope}) + \text{Intercept}$$

Note that 300 meters  $\approx$  500 psi  $\approx$  345 dbars

Please note that strain gauge pressure sensors are susceptible to atmospheric pressure changes and should be "zeroed" on each deployment or profile. The calibration equation for pressure above should be used first to get the relative pressure and the cast offset should then be subtracted to get the absolute pressure:

$$\text{Absolute Pressure (dbar)} = \text{Relative Pressure (dbar)} - \text{Relative Pressure at Atmospheric/Water interface (dbar)}$$

## **WARNING!**

**Do not exceed the pressure sensor's depth rating (see calibration sheet).**

A plastic fitting filled with silicone oil provides a buffer between the pressure transducer and seawater. The transducer is both sensitive and delicate. Following the procedures below will ensure the best results and longest life from your pressure sensor.

Pressure is transmitted from the water to the stainless steel transducer diaphragm via a plastic fitting filled with silicone oil. The inert silicone oil protects the pressure sensor from corrosion, which would occur after long exposure to salt water. The fitting will generally prevent the oil from escaping from the reservoir into the water. However, you may occasionally wish to ensure that oil remains in the reservoir on top of the transducer.

## **WARNING**

**Never touch or push on the transducer.**

1. Thoroughly clean the top of the instrument.
2. Completely remove the white nylon Swagelock fitting using a 9/16-in. wrench.
3. Check for obstructions in the tiny hole. Blow clear with compressed air or use a small piece of wire.
4. Wipe clean the o-ring at the base of the Swagelock fitting.
5. Screw the Swagelock fitting into the end flange until finger tight.
6. Tighten it an additional 1/8 turn using a wrench only if necessary.
7. Wipe up any excess oil.

## 2. Theory of Operation

The angular distribution of scattered radiation in the backward hemisphere is important in the interpretation of remote sensing measurements, investigations of particle shape, and models of visibility in seawater. The *ECO* VSF measures the optical scattering at 100, 125, and 150 degrees, thus providing the shape of the Volume Scattering Function (VSF) throughout its angular domain. Motivated by the need to better understand the relationship of water-leaving radiance with the backscattering into the same direction, the three-angle measurement allows determination of specific angles of backscattering through interpolation. Conversely, it also can provide the total backscattering coefficient by integration and extrapolation from 90 to 180 degrees.

Figure 3 shows the optical configuration for the VSF. The *ECO* VSF consists of a potted monolithic optical flange and a housing containing the signal processing and controller circuitry. The optics include three LED-based transmitters that couple to a single receiver. The transmitters and receiver are located to establish centroid light scattering angles of approximately 100, 125, and 150 degrees respectively. For each angle the region of intersection encompasses a FWHM bandwidth of about 18 degrees.

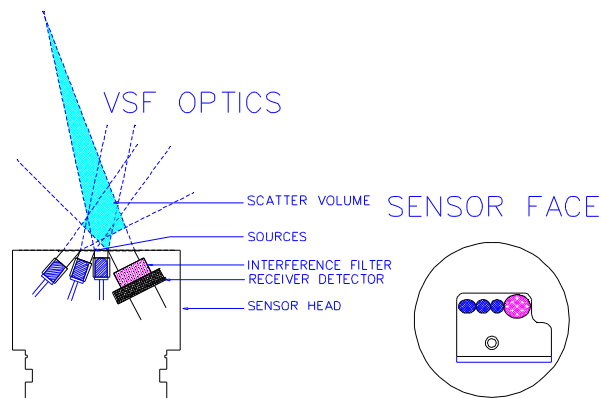

**Figure 3.** Optical configuration of *ECO*-VSF

The controller electronics sequence through the individual transmitters at approximately 1 Hz per sample cycle. The individual transmitters operate synchronously with the receiver to reject ambient light. A directly coupled reference detector indicates relative LED intensity during operation. Signals from the receiver and reference detector are digitized and subsequently stored or telemetered from the instrument.

The *ECO* VSF can be configured for a variety of applications. In addition to providing a continuous output, the instrument can internally record up to 65,000 samples of data. Additionally, for long-term deployments, the instrument can come equipped with an anti-fouling shutter to retard bio-fouling of the optical surfaces. Models with internal and external batteries are also available. Each sensor operates at one wavelength. Presently these wavelengths are factory configurable for 470 nm, 530 nm, and 650 nm.

### 3. Instrument Operation

Please note that certain aspects of instrument operation are configuration-dependent. These are noted where applicable within the manual. *ECO* sensors can be used in a moored or profiling mode, with or without a host computer/data logger. The *ECOs* are versatile instruments, capable of operating under a variety of user-selected settings

#### 3.1 Initial Checkout

Supplied from the factory, *ECOs* are configured to begin continuously sampling upon power-on. Electrical checkout of *ECO* is straightforward.

Connect the 6-socket connector on the test cable to the instrument to provide power to the LEDs and electronics (see Section 1 for a diagram of the pinouts of *ECO VSF*). Connect the battery leads on the test cable to the 9V battery supplied with the meter. Light should emanate from the meter.

#### 3.2 Operating the Sensor for Data Output

##### Note

*ECO* scattering meters are sensitive to AC light. Before making measurement, turn AC lighting off.

---

1. Connect the 6-socket connector to the instrument to provide power to the LEDs and electronics. Connect the DB-9 connector to a computer with the ECOView host program installed on it.

##### WARNING!

**Always use a regulated power supply to provide power to ECO sensors if not using the 9V battery provided with the test cable: power spikes may damage the meter.**

---

2. Start ECOView. Select the appropriate COM Port and Device File. Supply power to the meter, then click on the **Start Data** button. Output will appear in the Raw Data window. Place the flat of your hand in front of the sensor face and note that the signal will increase toward saturation (maximum value on calibration sheet) as your hand gets closer. When applying power to sensors with a *bio-wiper*<sup>TM</sup>, it will open and, depending on the settings, operate until you select **Stop Data** in ECOView (or input ! ! ! ! ! in a terminal program) The *bio-wiper*<sup>TM</sup> will close and the instrument will await the next command.
3. If the sensor completes the requested samples (this is common for meters set up in moored applications), it will go into sleep mode, and the meter will not light when power is cycled. To “wake” the meter, click **Stop Data** five times at the rate of two times per second immediately upon applying power. This interrupts the sensor, returning it to a “ready” state, awaiting commands.

- 
4. Check the settings for the ECO and change if necessary. ECOView factory settings for continuous operation:
    - Set Number of Samples = 0
    - Set Number of Cycles = 0.
  5. If the meter does not light after performing step 3, check the battery. Replace if necessary, perform steps 2 and 3 to verify communication. If it still does not light, contact WET Labs.

Refer to the ECOView User's Guide for details about using the software.

### 3.3 *Bio-wiper*<sup>™</sup> Operation

The *ECO*-VSFS and -VSFSB are provided with an anti-fouling *bio-wiper*<sup>™</sup> (Figure 4). The *bio-wiper*<sup>™</sup> extends the possible deployment duration by retarding biological growth on the instrument's optical surface. The *bio-wiper*<sup>™</sup> covers the optical surface: 1) while the instrument is in "sleep" mode; 2) when it has completed the number of samples requested; and 3) when the user selects **Stop Data** in ECOView or types "!!!!" in a terminal program. When the meter wakes up, the optical surface is exposed by the *bio-wiper*'s<sup>™</sup> counter-clockwise rotation.

#### **WARNING!**

Do **NOT** rotate the *Bio-wiper*<sup>™</sup> manually. This voids the warranty.

---

If power is shut off in mid cycle, the *bio-wiper*<sup>™</sup> will reinitialize to the beginning of the user-selected settings when power is applied again.

### 3.4 Deployment

The *ECO* VSF meter requires no pump to assure successful operation. Once power is supplied, the unit is ready for submersion and subsequent measurements. Some consideration should be given to the package orientation. Do not face the sensor directly into the sun or other bright lights. For best output signal integrity, locate the instrument away from significant EMI sources.

#### **Caution**

The VSF should be mounted so that the LED source will not "see" any part of a cage or deployment hardware. This will affect the sensor's output.

---

Other than these basic considerations, one only needs to make sure that the unit is securely mounted to whatever lowering frame is used and that the mounting brackets are not damaging the unit casing. The instrument can be used in a moored or profiling mode.

## 3.5 Upkeep and Maintenance

We highly recommend that ECO meters be returned to the factory annually for cleaning, calibration and standard maintenance. Contact WET Labs or visit our website for details on returning meters and shipping.

After each cast or exposure of the instrument to natural water, flush with clean fresh water, paying careful attention to the sensor face. Use soapy water to cut any grease or oil accumulation. Gently wipe clean with a soft cloth. The sensor face is composed of ABS plastic and optical epoxy and can easily be damaged or scratched.

### WARNING!

**Do not use acetone or other solvents to clean the sensor.**

---

#### 3.5.1 *Bio-wiper*<sup>TM</sup> and Faceplate Cleaning and Maintenance

The *bio-wiper*<sup>TM</sup> and the copper faceplate need to be removed from the meter for thorough cleaning to maximize anti-fouling capability.

1. Be sure the meter is **NOT** powered or connected to a power source prior to uninstalling the *bio-wiper*<sup>TM</sup> and faceplate.

### WARNING!

**Manually turning the motor shaft can damage the wiper motor and will void the warranty.**

**Make sure the *bio-wiper*<sup>TM</sup> is loosened from the shaft before attempting to rotate the *bio-wiper*<sup>TM</sup>.**

---

2. Remove *bio-wiper*<sup>TM</sup>: Use the factory-supplied 3/32-in. hex key to loosen the screw that secures the wiper to the shaft on the instrument. It may be necessary to remove the screw from the clamping hole and screw it into the releasing hole, tightening it just enough to free the *bio-wiper*<sup>TM</sup> from the shaft.

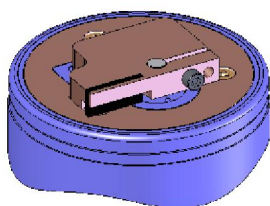

clamping screw hole

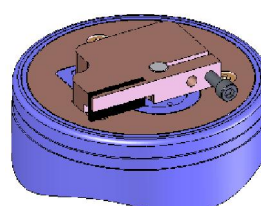

releasing screw hole

---

### WARNING!

**Be sure to retain and re-use the factory-installed screws as they are vented for pressure compensation.**

---

3. Remove faceplate: Use a small Phillips screwdriver to remove the screws that attach the plate to the optics head.

4. Wash *bio-wiper*<sup>™</sup> and/or copper faceplate with soapy water. Rinse and dry thoroughly. Note the condition of the copper on the instrument side of the wiper. It is normal for copper to corrode and turn green, especially after the instrument has been removed from the water. This corrosion will slightly reduce the shutter's anti-fouling ability the next time it is deployed.
5. Buff each with a pad of green Scotch Brite<sup>®</sup> (or similar) until shiny.
6. Clean the *bio-wiper*<sup>™</sup> shaft and the shaft hole using an isopropyl alcohol-saturated cotton swab. Allow to dry.
7. Re-install faceplate.
8. Check the screw used to secure the bio-wiper to the shaft: a hex key must fit snugly into the screw socket. If the socket is in any way compromised, use a new screw (4-40 x 3/8 in. 316 stainless steel treated with anti-seize. These are shipped as part of the meter's spare parts kit.)
9. Slide the *bio-wiper*<sup>™</sup> over the shaft. Be careful not to twist it on, thus rotating the shaft. If the wiper does not slide on easily, insert the screw into the expander hole, turning slowly until the *bio-wiper*<sup>™</sup> slides easily onto the shaft.
10. Rotate the *bio-wiper*<sup>™</sup> into the closed position.

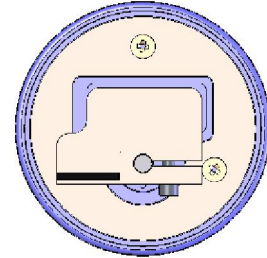

11. Set the gap between the *bio-wiper*<sup>™</sup> and the instrument face to 0.03 in. (0.8 mm). An improperly set gap will either fail to clean the face or cause the motor to draw excessive current.

To gauge 0.03 in., fold a piece of paper in half, then in half again, then fold a third time, creasing the edges. It's now 8 sheets and about 0.03 in. thick.

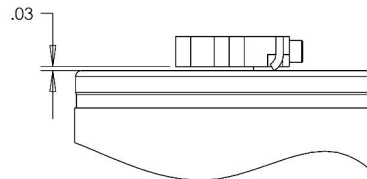

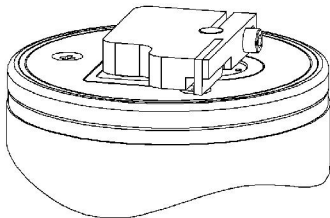

Not enough flex.

Wiper may not be effective.

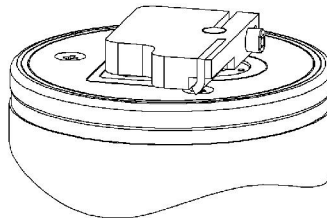

Proper flex.

Wiper maintains contact with instrument face and optical window.

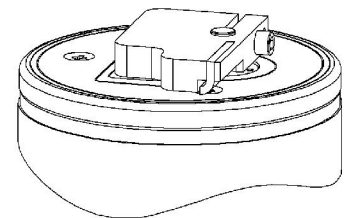

Too much flex.

Wiper may cause too much friction, using excessive power.

12. Use the 3/32-in. hex key to tighten the screw to “finger-tight,” then snug an additional quarter-turn.
13. Run the instrument to verify operation. The *bio-wiper*™ must rotate 180 degrees to clear the optics before sampling, and 180 degrees to cover the optics after sampling.
14. If the wiper needs adjusting, loosen the screw, make any necessary adjustments, and repeat steps 9 through 13 to ensure the wiper is performing properly.

#### 4. VSFB and VSFSB: Using Internal Batteries

ECO meters with internal batteries can be powered in several ways.

1. The meter can be powered from the six-pin bulkhead connector using the test cable (set to ON BATT) or from an external source (test cable set to ON AUX). Communication is possible in this mode.
2. Alternatively, the meter can be powered using a jumper plug in the three-socket bulkhead connector. This is particularly useful for moored applications. The meter will run according to its stored settings.
3. If the jumper plug is in place on the meter and supplying power and the test cable is connected, power will be supplied by the equipment supplying the highest voltage. To conserve the internal batteries, it is advisable to use the test cable and an external power source set to 10–15 V.

##### 4.1 Removing End Flange and Batteries

### WARNING!

**Changing the batteries will require opening the pressure housing of the ECO sensor. Only people qualified to service underwater oceanographic instrumentation should perform this procedure. If this procedure is performed improperly, it could result in catastrophic instrument failure due to flooding or in personal injury or death due to abnormal internal pressure as a result of flooding.**

**WET Labs Inc. disclaims all product liability from the use or servicing of this equipment.**

**WET Labs Inc. has no way of controlling the use of this equipment or of choosing qualified personnel to operate it, and therefore cannot take steps to comply with laws pertaining to product liability, including laws that impose a duty to warn the user of any dangers involved with the operation and maintenance of this equipment. Therefore, acceptance of this equipment by the customer shall be conclusively deemed to include a covenant by the customer to defend and hold WET Labs Inc. harmless from all product liability claims arising from the use and servicing of this equipment. Flooded instruments will be covered by WET Labs Inc. warranties at the discretion of WET Labs, Inc.**

---

1. Make sure the instrument is thoroughly dry.
2. Remove the dummy plugs.
3. With connector end flange pointed downwards away from face, release seal vent plug.
4. Remove moisture from vent plug area.
5. Using needle nose pliers, remove filament from end flange.
6. Lift flange from pressure housing until seal is broken. The jacking screws provided with sensor can be used to “push” the flange from the pressure housing and can then be removed or left in the end flange.
7. Remove excess moisture from flange–can seal area.
8. Work the end flange out of the pressure housing and remove any residual moisture. Remove the foam spacer and the neoprene insulator.

9. The battery pack is connected to the processor boards by a six-pin Molex connector: do NOT pull too hard or far on the battery pack or it will come unplugged and the unit will need to be returned to WET Labs.
10. Gently pull the white cord at the loop to remove the battery pack from the pressure housing.
11. Remove the black plastic protectors from the ends of the long screws securing the batteries.
12. Loosen and remove the screws (3/16-in slotted driver).

## **4.2 Replacing End Flange and Batteries**

1. Replace the batteries
2. Re-install the screws:
  - Align the groove in each of the plates so the six-wire extension bundle will fit in it along its length.
  - Be careful not to cross-thread into the bottom end plate nor to over-tighten the screws.
  - If they are too tight, the fiber washers that act as separators between the batteries will flex.
  - Make sure there are equal amounts of screw threads protruding from the bottom end plate when they are secure. This will ensure the pack is straight and will fit into the pressure housing with no difficulty.
1. Re-install the black plastic protective covers on the ends of the screws.
2. Remove and check the pressure housing O-ring for nicks or tears. Replace if necessary. Before re-installing, apply a light coat of vacuum grease on the O-ring.
3. Carefully replace the battery pack in the pressure housing. Place the neoprene insulator on the battery assembly and lay the white cord on the top.
4. Plug in the two-pin, then the six-pin Molex connectors. Sensor operation can now be tested if desired.
5. Align the hole in the end flange (NOT the jack screw holes) with the white dowel pin. While coiling the six wire bundle and making sure none are pinched between the end flange and the pressure housing, position the flange on the housing. Leave space to re-insert the gray foam spacer, making sure the cut-out accommodates the vent plug screw.
6. Push the end flange all the way on to the pressure housing, making sure no wires are pinched. Be sure the vent plug does not pop up. If it does, you'll need to re-position the foam spacer.
7. Re-insert the monofilament.

## 4.3 Checking Vent Plug, Changing O-Rings:

If there is fouling on the vent plug, it should be cleaned and the two 010 O-rings replaced. Otherwise, this mechanism should be maintenance-free.

### **WARNING!**

**The pressure housing is made of plastic material that scratches easily. Do not let the screwdriver slip and scratch the can when removing or replacing the vent plug. Use a toothpick (something softer than the plastic) to remove the O-rings from the vent plug.**

---

1. Pull vent plug out about half way; hold plug while unscrewing the truss screw. When screw is removed, pull vent plug from end flange.
2. “Pinch” bottom O-ring around vent plug to form a small gap you can work a toothpick into. Use the toothpick to help roll the bottom O-ring off the plug.
3. Perform the same procedure with the top O-ring.
4. Clean the vent plug and vent plug hole using a dry lint-free tissue or cotton swab.
5. Lightly coat two undamaged or new O-rings with silicon grease. Install the top O-ring (nearest to large end of plug) first, then the bottom one.
6. Insert vent plug into its hole in the end flange and hold it while inserting the truss screw. Rotate the vent plug to begin tightening the screw. Finish tightening using a screwdriver, being careful not to overtighten truss screw.

### **Note**

A portion of the truss screw head has been removed to allow for venting in case of pressure buildup.

---

## 5. Data Analysis

Data from the *ECO* VSF represents raw output from the sensor. Applying linear scaling constants, this data can be expressed in meaningful forms of inverse meters for each of the respective angles.

### 5.1 Data Corrections

Attenuation coupling—Many scattering sensors require a subsequent attenuation correction for pathlength coupling of the transmitted and scattered light. This is typically a function of the propagation distances of the light as well as the magnitude of the water attenuation. Because the *ECO* VSF incorporates very short pathlengths and scattering volumes in its measurements, it is relatively immune to this pathlength coupling (Figure 6). For attenuation coefficients up to approximately  $4 \text{ m}^{-1}$  no data correction is required. If you are operating the meter in waters with greater turbidity, contact the factory for configuration information.

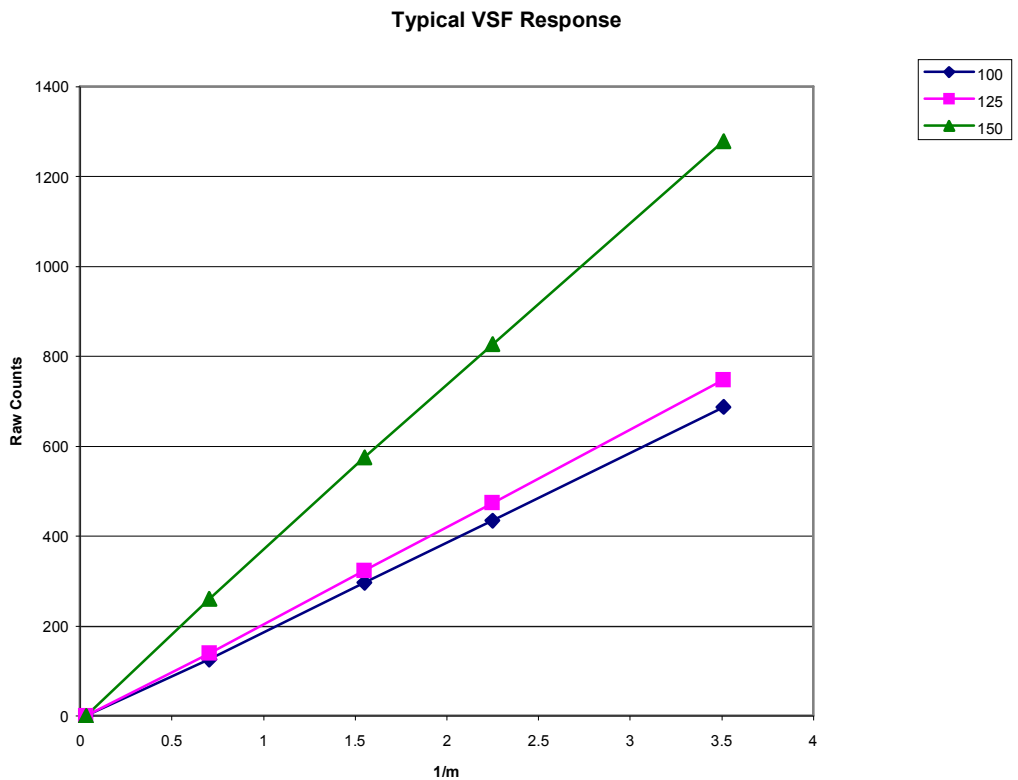

**Figure 4.** Linearity Response

---

Temperature correction—Output from an LED reference detector is provided, which gives an indication of relative LED intensity during operation.

Obtaining angular values in inverse meters—The primary angular values for each angle of backscattering are directly calculated by ECOView or alternatively can be applied upon raw data downloaded from the instruments. Determination is made by subtracting the clean water offset from the measured value and multiplying the result by the scaling factors provided in the calibration sheet.

The scaling coefficients for these values are determined by our instrument calibration process as described in Section 6.2.

## 5.2 Determining other Angle-Specific Coefficients

Other angular scattering coefficients can be determined through interpolation between the measured angles. At this time WET Labs offers no preference in the type of curve fit to use for deriving these coefficients.

### 5.2.1 Determining Backscattering Coefficient

The most accurate method of determining the backscattering coefficient,  $b_b$ , from the VSF measured at the three angles of the *ECO* VSF is as follows:

1. Multiply the corrected  $\beta$  values by  $2\pi\sin\theta$  to convert to a polar steradian area.
2. Fit a 3rd order polynomial to the three measured points and a fourth value of  $\pi$  radians = 0 ( $\sin(\pi \text{ radians}) = 0$ ).
3. Integrate under the curve fit from  $\pi/2$  to  $\pi$  radians.
4. Add 1.3 percent to the backscattering estimate.

Testing this approach with all the Petzold (1972) VSFs results in a maximum error of about 1 percent.

(Petzold, T.J., 1972. *Volume scattering functions for selected natural waters*. Scripps Institution of Oceanography, Visibility Laboratory, San Diego, CA, SIO Ref. 71–78.)

## **6. Testing and Calibration**

Prior to shipment, each *ECO* is characterized to ensure that it meets the instrument's specifications.

### **6.1 Testing**

When the instrument is completely assembled, it goes through the tests below to ensure performance.

#### **6.1.1 Dark Counts**

The meter's baseline reading in the absence of source light is the dark count value. This is determined by measuring the signal output of the meter in clean, de-ionized water with black tape over the detector.

#### **6.1.2 Pressure**

To ensure the integrity of the housing and seals, *ECOs* are subjected to a wet hyperbaric test before final testing. The testing chamber applies a water pressure of at least 50 PSI.

#### **6.1.3 Mechanical Stability**

Before final testing, the *ECO* meters are subjected to a mechanical stability test. This involves subjecting the unit to mild vibration and shock. Instrument functionality is verified afterwards.

#### **6.1.4 Electronic Stability**

This value is computed by collecting a sample once every 5 seconds for twelve hours or more. After the data is collected, the standard deviation of this set is calculated and divided by the number of hours the test ran. The stability value must be less than 3 counts.

#### **6.1.5 Noise**

The noise value is computed from a standard deviation over 60 samples. These samples are collected at one-second intervals for one minute. A standard deviation is then performed on the 60 samples, and the result is the published noise on the calibration form. The calculated noise must be below 3 counts.

#### **6.1.6 Voltage and Current Range Verification**

To verify that the *ECO* operates over the entire specified voltage range (7–15 V), a voltage-sweep test is performed. *ECO* is operated over the entire voltage range, and the current and operation is observed. The total power consumption (voltage times current) must remain below 600 mW over the entire voltage range.

### **6.2 Calibration**

Calibration of the *ECO* VSF involves the following steps.

1. Numerical determination of the volume weighted angular region for each scattering angle.

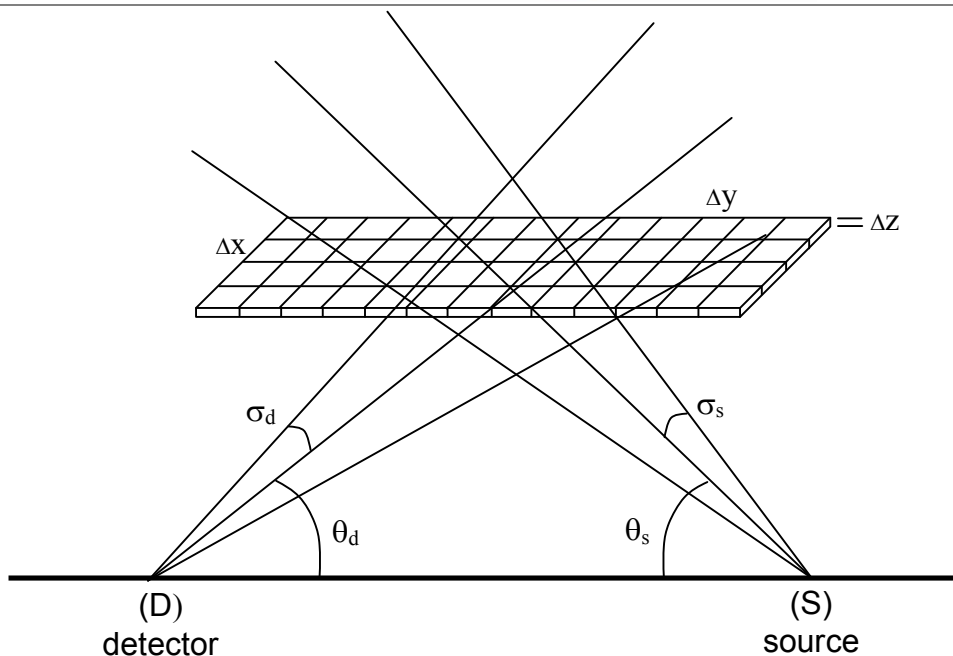

**Figure 5.** General geometry of the sensor

The detector (D) and the source (S) are separated by a distance SD.

The angle of the center of the detector beam with the line SD is  $\theta_d$ .

The half-angle of the detector cone is  $\sigma_d$ .

The corresponding angles for the source are  $\theta_s$  and  $\sigma_s$ .

The volume above the SD line is broken up into the small volumes  $\Delta x \Delta y \Delta z$ . z is in the same plane as the SD line.

The small volume,  $\Delta V = \Delta x \Delta y \Delta z$  at  $(x, y, z)$  was determined by simple geometry. It was then determined whether the  $\Delta V$  was in the intersection of the source beam and the field of view of the detector (both conical shapes). The intersection of each cone and the plane is an ellipse and the illuminated area is the intersection of those ellipses. The signal strength was determined for each elementary volume, and then integrated over the illuminated area to obtain the weighting function. Weighting functions were determined in this manner for each source–detector pair (nominal angles of 100, 125, and 150 degrees) and are plotted in the figure below.

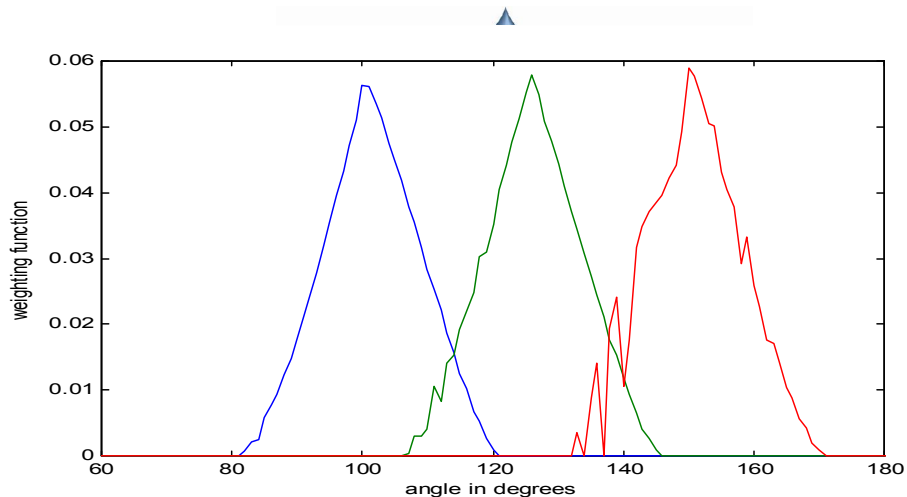

**Figure 6.** Weighting functions for source–detector pairs

2. Mie scattering determination into these regions for a known distribution of spherical scatterers (Polystyrene beads).

Spherical or spheroid particles with a known particle size distribution can be quite accurately modeled for scattering behavior using Mie theory. We thus obtain NIST-traceable bead standards and calculate their scattering response using the derived weighting functions.

3. Determination of angular coefficients through direct measurement of spherical beads.

Once the weighting functions are determined and the scattering response for our calibration medium determined, we then run a dilution series of measurements, using the medium in water. From the curves obtained with varying concentration we then calculate the absolute response of the instrument. These are the scaling coefficients supplied with each instrument.

## 7. General Terminal Communications

While WET Labs supplies a host software package for instrument configuration and data retrieval, the unit sensors can be controlled from a terminal emulator or customer-supplied interface software. This section outlines hardware requirements and low-level interface commands for this type of operations.

### 7.1 Communication Settings

baud rate: 19200  
 data bits: 8  
 parity: none  
 stop bits: 1  
 flow control: none

### 7.2 ECO Command List and Data Format

Command	Parameters passed	Description
!!!!	none	Stops data collection; allows user to input setup parameters. Note that if the meter is in a sleep state, the power must be turned off for a minute, then powered on while the “!” key is held down for several seconds. If this does not “wake” the meter, refer to the ECOView user’s guide Operation Tip to “wake” a meter in a low power sleep state to enable inputting setup parameters.
\$ave	single number, 1 to 65535	Number of measurements for each reported value
\$elk	24hr format time, hhmmss	Sets the time in the Real Time Clock
\$dat	date, format ddmmyy	Sets the date in the Real Time Clock
\$emc	none	Erases the Atmel memory chip, displays menu when done
\$get	none	Reads data out of Atmel memory chip. Prints "etx" when completed.
\$int	24hr format time, hhmmss	Time interval between packets in a set
\$mnu	none	Prints the menu, including time and date
\$pkt	single number, 0 to 65535	Number of individual measurements in each packet
\$rec	1 (on) or 0 (off)	Enables or disables recording data to Atmel memory chip
\$rls	none	Reloads settings from flash
\$run	none	Executes the current settings
\$set	single number, 0 to 65535	Number of packets in a set
\$sto	none	Stores current settings to internal flash

## **8. Device and Output Files**

Each meter is shipped with a CD containing the meter-specific device file, a sample output file, characterization information, and the applicable user's guides.

The ECOView host program requires a device file to provide engineering unit outputs for any of its measurements. Except for the first line in the device file, all lines of information in the device file that do not conform to one of the descriptor headers will be ignored. Every ECOView device file has three required elements: Plot Header, Column Count Specification, and Column Description.

### **8.1 Plot Header**

The first line in the device file is used as the plot header for the ECOView plots.

### **8.2 Column Count Specification**

The Column Count Specification identifies how many columns of data to expect. It follows the format "Column=n." The Column Count Specification must be present before any of the Column Descriptions are listed.

### **8.3 Column Description**

Every column in the ECO meter's output must have a corresponding Column Description in the device file. The following notation is used in identifying the elements of each Column Description.

x = the column number, starting with 1 as the 1<sup>st</sup> column

sc = scale

dc = dark counts: meter output in clean water with optics head taped

mw = measurement wavelength—wavelength used by the sensor for its measurement

dw = display wavelength—display wavelength—wavelength/color range (380–780 nm)

v = measured volts dc (not used on VSF)

Valid Column Descriptions are listed below.

Date=x	MM/DD/YY
Time=x	HH:MM:SS
N/U=x	The column is Not Used
N/U=x	The column is Not Used

#### 8.4 Sample Device File

Below is the standard device file for a VSF at 530 nm.

```
ECO VSF-059g
Created on: 10/30/03
```

```
Columns=7
Date=1
Time=2
N/U=3
vsf100=4      1.36E-03      73
vsf125=5      1.46E-03      86
vsf150=6      1.39E-03     103
N/U=7
```

#### 8.5 Sample Output File

Below is a sample output file for a VSF. From left to right, columns describe:

1. Date (MM/DD/YY)
2. Time (HH:MM:SS)
3. Not used
4. 100 degree angle output signal
5. 125 degree angle output signal
6. 150 degree angle output signal
7. Thermistor

<b>Date</b>	<b>Time</b>	<b>λ</b>	<b>100°</b>	<b>125°</b>	<b>150°</b>	<b>Therm</b>
9/17/2003	13:11:20	530	165	173	400	543
9/17/2003	13:11:21	530	168	176	396	543
9/17/2003	13:11:22	530	162	176	396	542
9/17/2003	13:11:23	530	167	177	394	542
9/17/2003	13:11:24	530	163	174	392	542
9/17/2003	13:11:25	530	167	174	396	542
9/17/2003	13:11:26	530	163	180	398	542
9/17/2003	13:11:27	530	168	176	390	542
9/17/2003	13:11:28	530	166	174	393	542

## Appendix A: Mounting Bracket Drawing

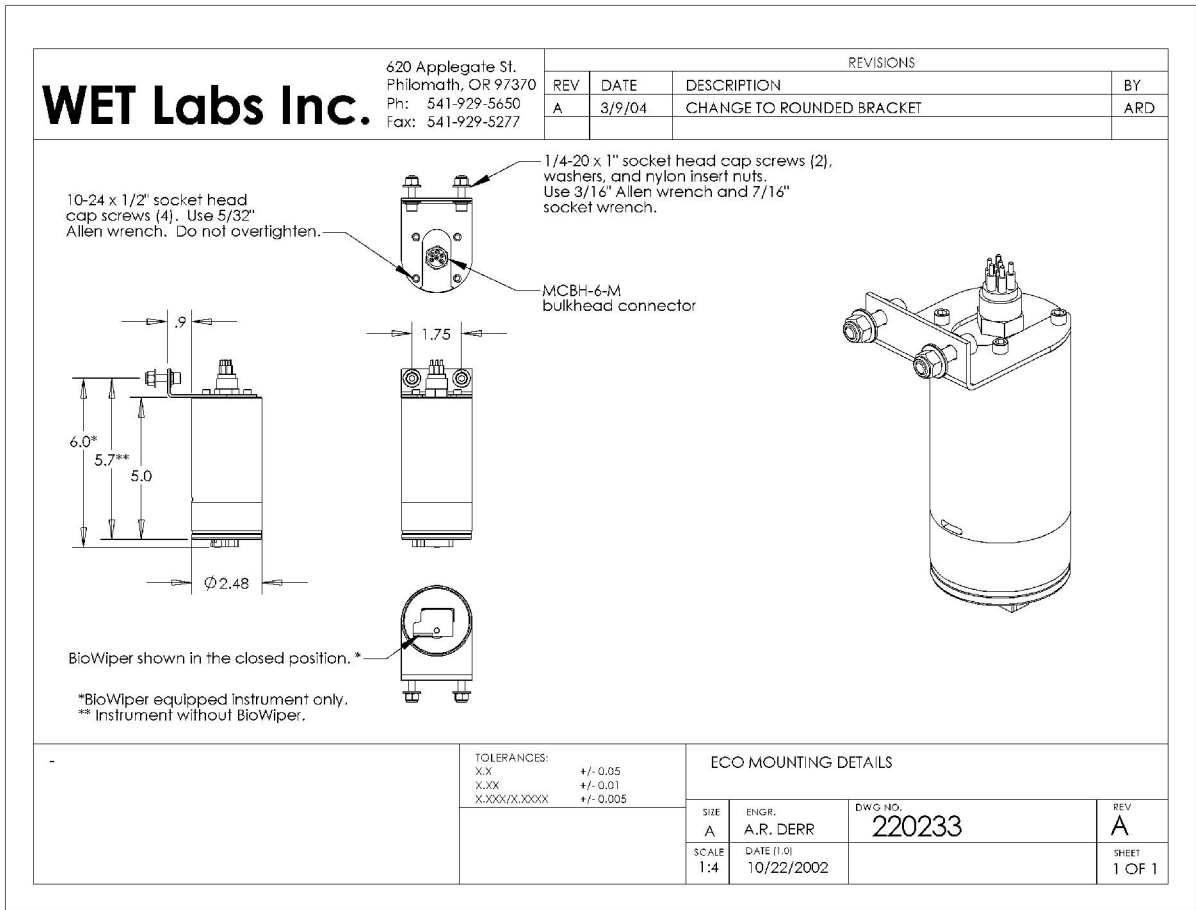



---

## **WET Labs WEEE Policy**

In accordance with Directive 2002/96/EC and the Council of 27 January 2003, WET Labs policy regarding the collection and management of Waste Electrical and Electronic Equipment (WEEE) is published here and is available at [www.wetlabs.com](http://www.wetlabs.com).

A core component of our corporate vision is to accept responsibility for preserving our environment and we embrace the opportunity to work with our customers and the EU to reduce the environmental impact resulting from the continuous improvement of our products.

### **WEEE Return Process**

To meet the requirements of the WEEE Directive, WET Labs has instituted a product end-of-life take back program. To arrange return for an end-of-life WEEE product:

1. Contact WET Labs Customer Service
  - By phone: 1-541-929-5650
  - By email: [support@wetlabs.com](mailto:support@wetlabs.com)

WET Labs will provide:

WEEE RMA number

Shipping account number, method, and address

2. Package and ship the WEEE back to WET Labs

WEEE will be processed in accordance with WET Labs' equipment end-of-life recycling plan.

### Revision History

Revision	Date	Revision Description	Originator
A	04/06/00	New document (DCR 22)	C. Carlock, C. Moore, W. Strubhar
B	09/20/00	Add vent plug maintenance steps (DCR 55)	D. Whiteman
C	09/25/00	Add explanation of ECO Host date format (DCR 56)	C. Carlock
D	10/18/00	Add lithium battery warning (DCR 65)	H. Van Zee
E	10/31/00	Add ECO Host 4, Shuttered specs, jumper plug note (DCR 68)	C. Carlock, H. Van Zee
F	11/13/00	Add aux. output explanation (DCR 72)	W. Strubhar
G	01/18/01	Correct setup and testing procedure, explanation of Interrupt Autostart on shuttered units (DCR 78)	C. Carlock
H	07/12/01	Update to ECO Host v. 4.1.2 (DCR 130)	C. Carlock
I	09/18/01	Add spare monofilament and plastic bar stock to shipping list (DCR 146)	H. Van Zee
J	11/5/01	Change LED wavelength values (DCR 159)	H. Van Zee
K	11/15/01	Add references to device file (DCR 161)	D. Whiteman
L	01/16/02	Update reference to test cable (DCR 185)	M. Avery
M	03/13/02	Correct VSFS/VISFB weights (DCR 201)	H. Van Zee
N	04/10/02	Update Section 3 (DCR 204)	D. Whiteman
O	04/16/02	Add max. samples to specifications (DCR 215)	D. Whiteman
P	07/08/02	Add internal battery option to spec. table (DCR 228)	H. Van Zee
Q	07/25/02	Delete inaccurate references to shutter specifications (DCR 238)	H. Van Zee
R	2/10/03	Delete lithium battery warning (DCR 272)	D. Whiteman
S	2/24/03	Change "shutter" to "bio-wiper™" (DCR 280)	H. Van Zee
T	4/14/03	Add stop command to terminal communications (DCR 292)	W. Strubhar
T1	10/30/03	Delete references to ECO Host, update to round board specs (draft)	H. Van Zee
U	11/24/03	Delete references to ECO Host, update to round board specs (DCR 344)	D. Romanko, H. Van Zee, D. Whiteman
V	11/25/03	Update Specifications (DCR 338)	I. Walsh
W	2/17/04	Update bio-wiper maintenance and column description for device files (DCR 367)	A. Derr, I. Walsh
X	3/10/04	Add new test cable description, operational description, mounting diagram (DCR 381)	A. Derr, D. Whiteman
Y	5/11/04	Remove pin 6 from warning in section 1 (DCR 390)	I. Walsh
Z	6/29/04	Update Specifications (DCR 400)	I. Walsh
AA	9/28/04	Add text for optional thermistor and pressure sensor (DCR 429)	I. Walsh
AB	10/14/04	Add references to Lithium batteries for applicable models (DCR 433)	I. Walsh
AC	7/26/05	Replace Clean Water Offset with Dark Counts (DCR 468)	M. Johnson
AD	1/13/06	Clarify warranty statement (DCR 481)	A. Gellatly, S. Proctor
AE	5/31/06	Add annual maintenance recommendation (DCR 498)	S. Proctor
AF	6/28/06	Cleaning and maintenance of modified bio-wiper (ECN 230, DCR 502)	A. Derr, H. Van Zee
AG	7/27/06	Change length of securing screw on bio-wiper (ECN # not assigned; DCR 504)	J. da Cunha, H. Van Zee
AH	9/26/06	Update specifications (DCR 507)	M. Johnson
AH1	10/30/06	Correct Pressure Sensor and Thermistor output calculations (draft)	M. Johnson
AI	11/1/06	Finalize pressure sensor and thermistor output calculations (DCR 509)	M. Johnson
AJ	9/11/07	Delete reference to refilling pressure sensor, update shipping requirements (DCR 531)	M. Johnson, H. Van Zee



---

AK	7/10/08	Change dark counts derivation to reflect current production methodology (DCR 600)	A. Barnard, M. Johnson, H. Van Zee
AL	9/8/08	Change reference column to N/U	M. Johnson, H. Van Zee
AM	9/21/10	Change LED from 660 to 650 nm (DCR 691)	H. Van Zee
AN	9/14/11	Add WEEE Statement (DCN 775)	H. Van Zee