

Power and Communication Conversion System

User's Guide

The user's guide is an evolving document. If you find sections that are unclear, or missing information, please let us know. Please check our website periodically for updates.

WET Labs, Inc.
PO Box 518
Philomath, OR 97370
(541) 929-5650
wetlabs@wetlabs.com

Return Policy for Instruments with Anti-fouling Treatment

WET Labs cannot accept instruments for servicing or repair that are treated with anti-fouling compound(s). This includes but is not limited to tri-butyl tin (TBT), marine anti-fouling paint, ablative coatings, etc.

Please ensure any anti-fouling treatment has been removed prior to returning instruments to WET Labs for service or repair.

Warranty

This unit is guaranteed against defects in materials and workmanship for one year from the original date of purchase. Warranty is void if the factory determines the unit was subjected to abuse or neglect beyond the normal wear and tear of field deployment, or in the event the pressure housing has been opened by the customer.

To return the instrument, contact WET Labs for a Return Merchandise Authorization (RMA) and ship in the original container. WET Labs is not responsible for damage to instruments during the return shipment to the factory. WET Labs will supply all replacement parts and labor and pay for return via 3rd day air shipping in honoring this warranty.

Shipping Requirements

1. Please retain the original shipping material. We design the shipping container to meet stringent shipping and insurance requirements, and to keep your meter functional.
 2. To avoid additional repackaging charges, use the original box (or WET Labs-approved container) with its custom-cut packing foam and anti-static bag to return the instrument.
 - If using alternative container, use at least 2 in. of foam (NOT bubble wrap or Styrofoam “peanuts”) to fully surround the instrument.
 - Minimum repackaging charge for PCCS meters: \$60.00.
 3. Clearly mark the RMA number on the outside of your shipping container and on all packing lists.
 4. Return instruments using 3rd day air shipping or better: do **not** ship via ground.
-

1. Overview

The Power and Communication Conversion System (PCCS) allows you to supply power from either a 110 or 220 VAC (50–60 Hz) outlet and communicate via a USB port. The PCCS has two components:

- The deck unit. Converts AC power to DC power and has a communication port.
- The submersible unit. Converts the DC power and outputs 12 VDC to the connected instrument.



Deck box with USB cable, software, power cord.
(Sea cable not shown.)



Submersible unit with patch cable

1.2 Deliverables

The PCCS ships with the following components:

- Deck box.
- ac power cord.
- Three foot long A–B USB cable.
- CD for installing PCCS communication software
- Sea cable (customer-specified length).
- Submersible unit.
- Patch cable (customer-specified length).
- This user's guide.

2. Specifications

2.1 Deck Box

<i>Height</i>	7.6 cm
<i>Width</i>	5.8 cm
<i>Length</i>	25.4 cm
<i>Weight</i>	0.9 kg
<i>Temperature range</i>	0–85 deg C
<i>Connectors</i>	<ul style="list-style-type: none">• 10-socket sea cable• USB• AC power
<i>Communication</i>	USB
<i>Input voltage</i>	110 to 220 VAC (50–60 Hz)
<i>Output, max.</i>	75 W

2.2 Submersible Power Converter

<i>Height</i>	10.1 cm
<i>Diameter</i>	10.1 cm
<i>Weight</i>	0.9 kg
<i>Pressure housing</i>	Acetal copolymer
<i>Rated depth</i>	600 m
<i>Input voltage</i>	48 VDC (from deck box)
<i>Output</i>	12 VDC
<i>Output, max</i>	75 W
<i>Connectors</i>	<ul style="list-style-type: none">• 10-pin sea cable input (from deck box)• 8-socket MCBH output

2.3 Connectors

The submersible unit has two bulkhead connectors:

1. An eight-socket output that connects customer-specified connectors for communication to the customer's instrument (typically 6-contact).
2. A ten-pin sea cable connector which goes to the PCCS deck unit.

The deck box of the PCCS has an AC power connector, one USB connector, and one 10-pin sea cable connector.

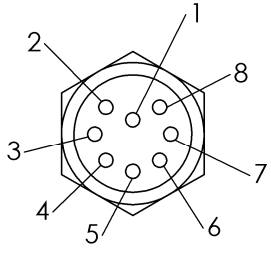
Pin	Function	Diagram
1	Ground	 <p style="text-align: center;">MCBH-8-FS</p>
2	RS-232 RX	
3	N/C	
4	V+	
5	RS-232 TX	
6	N/C	
7	N/C	
8	N/C	

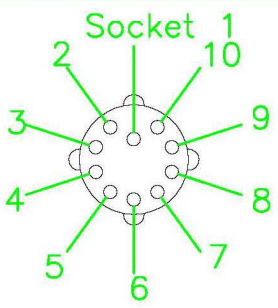
Pin	Function	Diagram
1	Ground	
2	RS-232 (RX)	
3	RS-422 Y (TX)	
4	V+ (48 V)	
5	RS-232 (TX)	
6	RS-422 Z (TX-INV)	
7	RS-422 A (RX)	
8	RS-422 B (TX-INV)	
9	N/C	
10	N/C	

3. Instrument Setup and Operation

The Power and Communication Conversion System (PCCS) submersible accepts a power input voltage of 48 volts (pin 4), from the deck box, and outputs 12 volts of regulated power from socket 2. Communication with the meter of choice is via the patch cable.

Note

The patch cable is an additional component of the PCCS and its length is customer-specified.
The connectors are typically 8-pin-to-6-socket.

Setting up and checking the functionality of the PCCS requires the following:

- deck box
- power converter
- patch cable
- host computer
- meter to generate data
- USB cable.

3.1 Install Communication Software

1. Connect the deck box to an AC power source.
2. Connect the 10-pin cable to the SEA CABLE connector on the deck box and the other end (sockets) to the submersible's connector.
3. Connect the USB cable to the deck box and host computer.
4. Insert the B&B Electronics CD in the host computer. Follow the Found New Hardware wizard to install 2 drivers:
 - USOPTL4 communications protocol
 - RS-485 Isolated Port, which effectively turns a USB port into a serial port.
5. The Found New Hardware Wizard starts automatically after you connect the USB cable.



6. Select Install the software automatically option. Select Next >

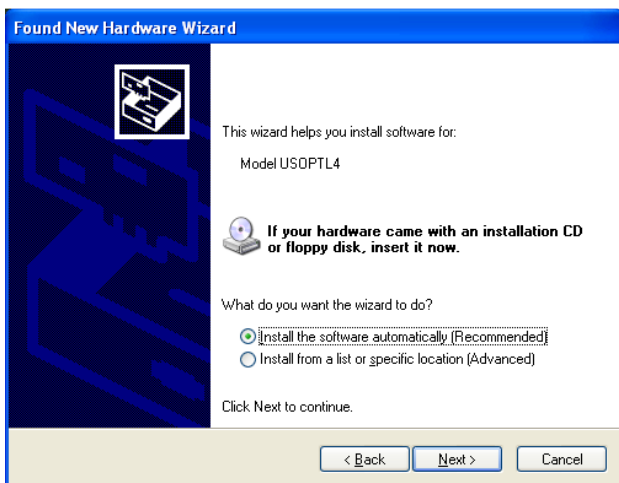

7. Select Finish.

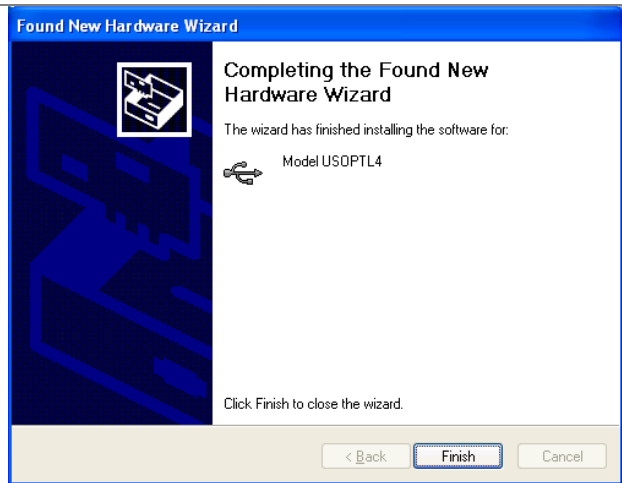

8. The next wizard prompts you to install the RS-485 Isolated Port. This is similar to the previous installation.

Follow the wizard through the steps as in the USOPTL4 installation.

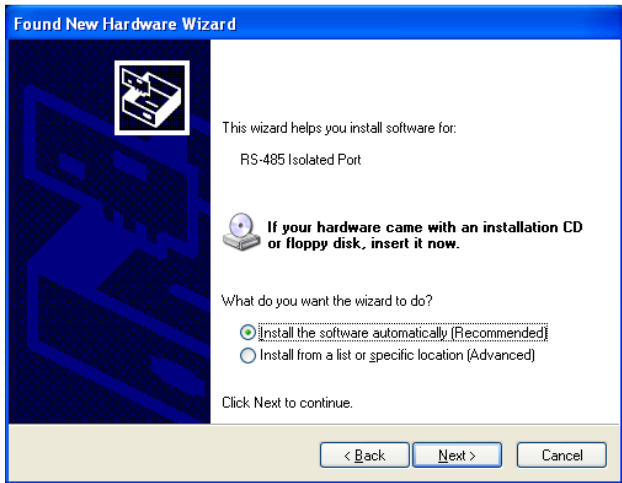

9. Select Finish.

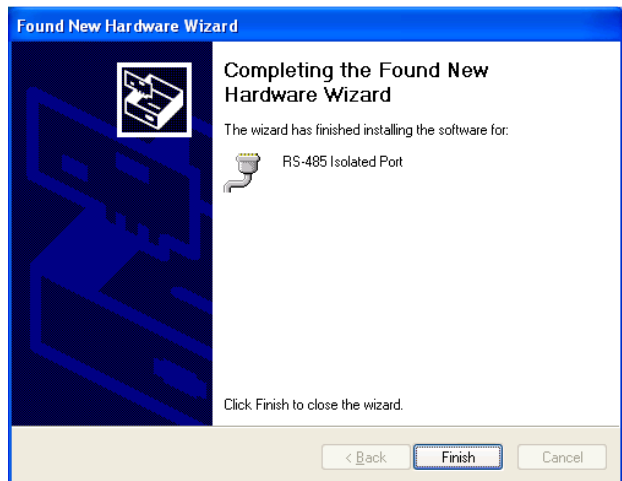

The PCCS deck box communications software is now installed.

3.2 Identify COM Port

The software assigns a COM port number to the USB port, which is identified via the host computer's device manager.

1. Open the host computer's Control Panel.
2. Select System.
3. Open the Hardware tab. Select Device Manager. In the list of devices in the resulting window, select Ports. You should see RS-485 Isolated Port and its assigned COM port. (COM5 in the example.)



4. Connect the patch cable to the submersible and the meter that will be generating data.
6. Test functionality:
 - Start HyperTerminal or other terminal program.
 - Select the COM port number shown from the Device Manager.
 - Select the Properties as shown below (19200, 8, none, 1, none).



19200: most WET Labs meters

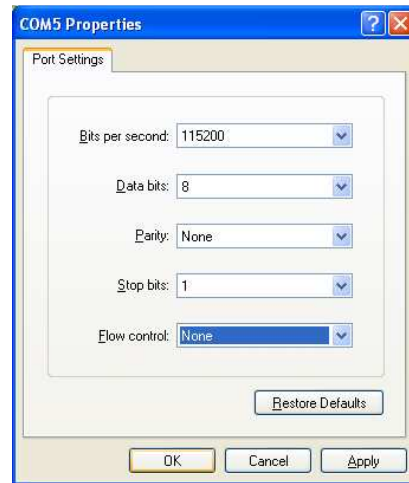

115200: acs meter

7. Turn power on at the deck box.

Header information and data should appear (depending on which meter you're testing), confirming communication.

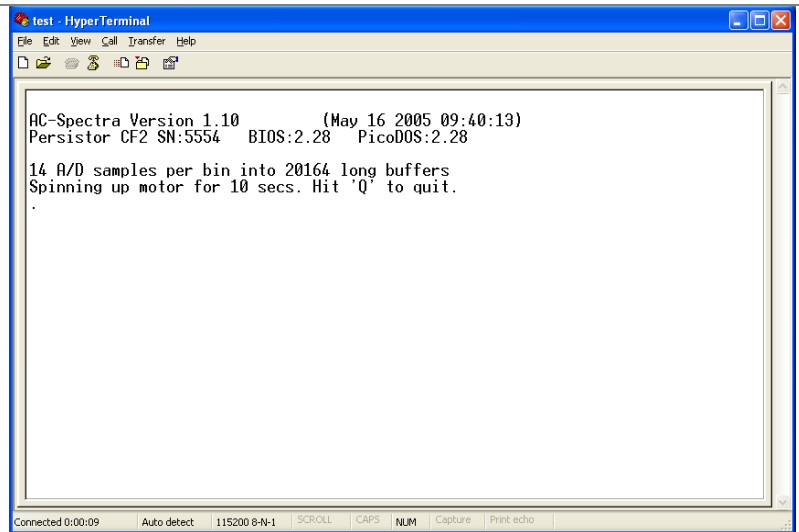

The image shows a screenshot of a HyperTerminal window titled "test - HyperTerminal". The window contains the following text:

```
AC-Spectra Version 1.10          (May 16 2005 09:40:13)
Persistor CF2 SN:5554  BIOS:2.28  PicoDOS:2.28

14 A/D samples per bin into 20164 long buffers
Spinning up motor for 10 secs. Hit 'Q' to quit.
.
```

The status bar at the bottom of the window displays: "Connected 0:00:09", "Auto detect", "115200 8-N-1", "SCROLL", "CAPS", "NUM", "Capture", and "Print echo".

3.3 Diagnostics

While the PCCS and meter are running, you can verify functionality at the deck box using the push-to-test buttons to verify

- 48 V power supply to the sea cable.
 - Transmit from the submersible unit.
1. The *RX* and *TX* light in the top of the deck box should light, indicating the meter is sending and receiving data via the USB port.
 2. When the deck box is receiving AC power, the power switch is backlit red.
 3. The sub unit is equipped with an indicator light that lights when the unit is receiving 12V power.
 - If the backlight on the power switch fails to light when AC power is supplied, check the 250V, 2 amp, 5 x 20 mm slow-blow fuse. It may need to be replaced.

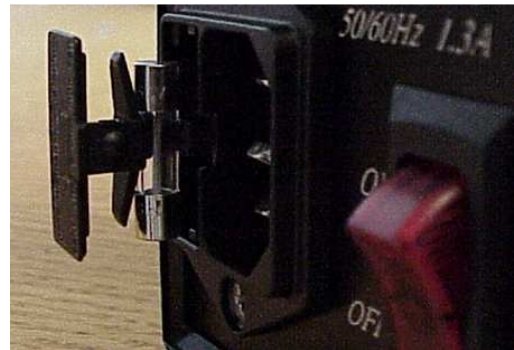

The ability to transmit settings to a data logger such as a DH-4 is accomplished using an 8-conductor cable. When sending settings to a data logger, the *TX* light will be lit.

Revision History

Revision	Date	Revision Description	Originator
A	8/31/03	New document (DCR 420)	M. Levin, H. Van Zee
B	12/23/04	Remove serial connector option (DCR 445)	M. Levin, H. Van Zee
C	3/17/05	Change equipment name (DCR 462)	I. Walsh
D	1/13/06	Clarify warranty statement (DCR 481)	A. Gellatly, S. Proctor
E	10/20/10	Add software loading instructions (DCR 670)	D. Stahlke, H. Van Zee
F	10/27/10	Revise software loading instructions (DCR 722)	D. Stahlke, H. Van Zee